

KEEP IT DRY



PX3-28-150

- 28kW
- 150mm
- Prime Vacuum Assisted
- Electric Driven Package
- Transportable Canopy Package

RH PUMPER A/S ▪ Stenrøjlervej 1 ▪ 4200 Slagelse
RH PUMPER AB ▪ Box 100 ▪ SE 311 21 Falkenberg
Tlf. +45 5850 6065 ▪ info@rhpumper.dk

WWW.RHPUMPER.DK



ISO 14001 ▪ ISO 45001 ▪ DS 21001

Mechanical drawing

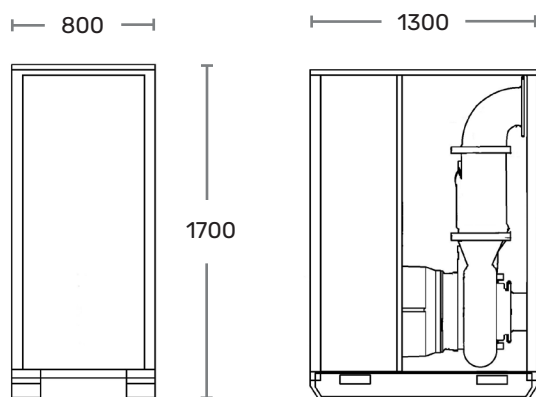

Performance curve

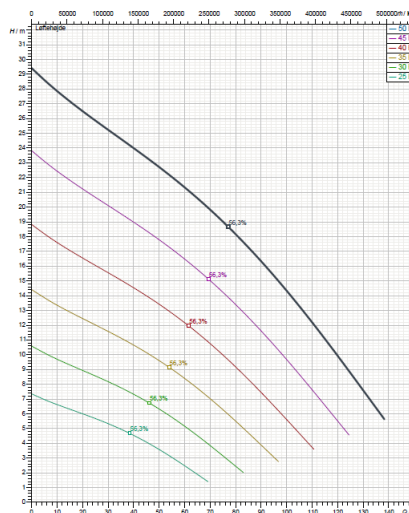

SPECIFICATIONS

Suction Connection	150 mm
Delivery Connection	150 mm
Max Flow	440 m³/h
Max Head	26 m
Solids Size	100 mm
Max Speed	1462 rpm
Rated Power BEP	28 kW
Sound Rating	65 dB 7 metres
L x W x H (mm)	1300 x 800 x 1700
Weight	980 kg

PRIME SYSTEM

Priming System

Mechanically Driven Vacuum Pump

Air Removal Capacity

50CFM

Priming Chamber

Single chamber with positive sealing air separation
PosiValve™ with stainless steel float ball & linkage.

Discharge Check Valve

Swing Style - ductile iron with Buna-n Disc completely dry without damage

FEATURES

- Indefinite Run-Dry Capability
- Efficient Design for Reduced Operating Costs
- Auto Stop/Start with floats/pressure transmitter
- Pump controller with Sim card for SRO monitoring
- Environmentally Safe Priming System with Patented PosiValve™ - No Blow By
- VFD controller

MOTOR SPECIFICATIONS

Cos Phi 0,795
28 kW 400V 58A

High Efficient Electrical motor
Safety Shutdown Switches High Temperature

APPLICATIONS

Raw Water Pumps
Dirty Water
Cooling Pumps

Flood pumps
Sewage Bypass
ByPass

Mine Dewatering
Flushing
Process water

OTHER SPECIFICATIONS

- Channel or vortex Impeller
- Fully welded and galvanized Frame
- Fork lifting pockets
- Oversized stainless steel shaft AISI 420
- Individual setup
- Large solids handling capability
- Run dry double tandem mechanical seal
- Connections Bauer and parrot
- Auto Start/stop control panel with VLT inverter
- Lifting pockets
- Lifting eyes on top
- Ductile iron GS500 impeller
- Telemetry monitoring
- 24/7 live data

CONSTRUCTION MATERIALS

STANDARD

OPTION

Impeller
Volute
Wear Ring
Suction Cover
Bracket
Backplate

Ductile
Ductile Iron
CD4MCu-316 SS
Ductile Iron
Ductile Iron
Ductile Iron

Stainless steel/duplex
Stainless steel/duplex
CD4MCu-316 SS
Stainless steel/duplex
Stainless steel/duplex
Stainless steel/duplex