

TECHNICAL DATA



• CONCEPT :

The Toyo DP3 to DP10 submersible pumps with agitator has been specially designed to handle very heavy and abrasive slurries.

These centrifugal pumps with semi-open impeller feature a unique agitator design. This agitator lifts sediments into suspension and creates a homogeneous mixture.. This enables the continuous pumping of media with a high concentration of solids.

Robust construction, careful selection of materials and unique contour components, coupled with a low speed high torque motor, have produced a pump with excellent abrasion resistance as well as a sufficient weight and an important torque. These characteristics ensure long service life and economical operation.

The impeller, the wear plate and the agitator are manufactured in cast chrome iron (24 to 28% Cr).

A strong short shaft supported by a series of carefully selected bearings and a double mechanical operating in an oil bath ensure tightness in the hardest of conditions.

Servicing and maintaining the pumps to keep them in good working order is easy. The adjustable wear plate allows simple adjustments to maintain long lasting high performance.

The electric class F motor is cooled by the liquid in which the pump is submerged.

DP3 to DP10 pumps are equipped with a thermal protection in standard version. They are available in different metallurgies and notably in stainless steel for acid slurries pumping.

These pumps can be provided with detachable bend and base.

• OPERATING CONDITIONS :

- slurries with solid content of up to 50% by weight
- particle sizes up to 25 mm
- liquid temperatures up to 60°C
- pH levels between 4 and 14

Special versions are available for liquid temperatures up to 80°C. Maximal operating depth is 30 m.

• ELECTRIC POWER REQUIREMENTS* :

Pump type	Power kVA	Amp. 400 V
DP 3	6	5
DP 5	12	8.3
DP 7.5/B	15	11.8
DP 10/H	20	16.3

*These figures are given as an indication.

• ELECTRIC CABLE :

The standard cable type to be used for connecting the pump is HO7RN-F and its specifications should correspond to the following:

Pump type	Section	Outer diam. mm	Max. length m / 400V
DP 3	4 x 6 mm ²	19	500
DP 5	4 x 6 mm ²	19	350
DP 7.5/B	4 x 10 mm ²	23	350
DP 10/H	4 x 10 mm ²	23	250

• CONTROL PANEL :

For DP3 to DP10 pumps, we recommend to use a Toyo control panel equipped with a direct starter.

TOYO PUMPS EUROPE

Parc Industriel Sud - Zone II
 Rue de l'Industrie 41 - BE - 1400 Nivelles - Belgium
 Tel. : +32(0)67 64 55 35/37 - Fax : +32(0)67 64 55 31
 E-mail : sales@toyopumpseurope.com
 Website : www.toyopumpseurope.com

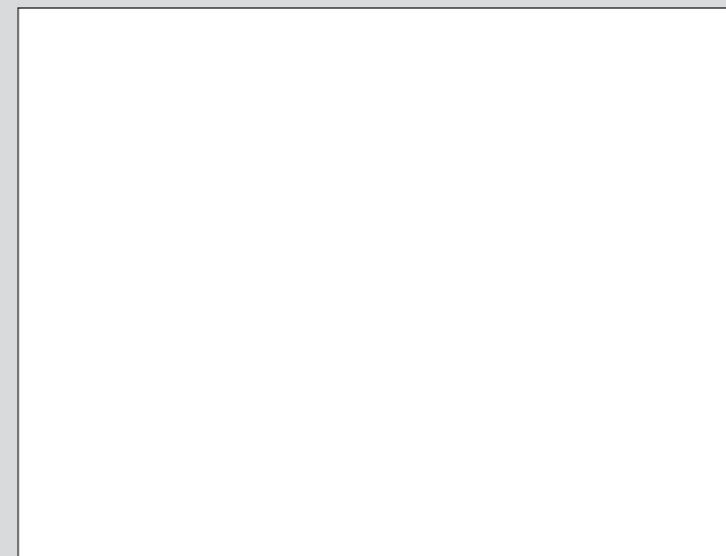
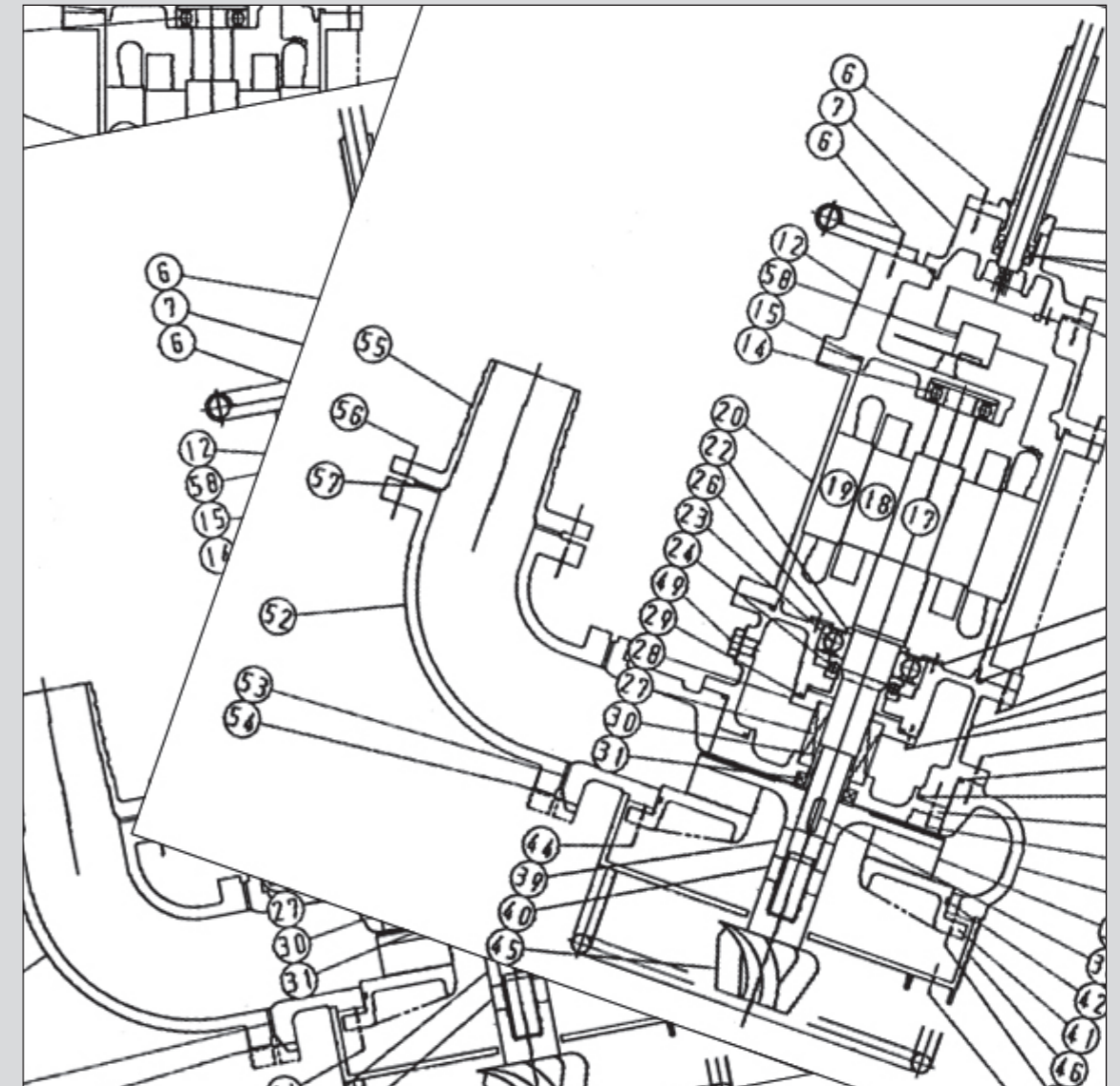

Heavy slurry pumps

**TECHNICAL SPECIFICATIONS
 DP3 TO DP10 PUMPS**

Performance curves

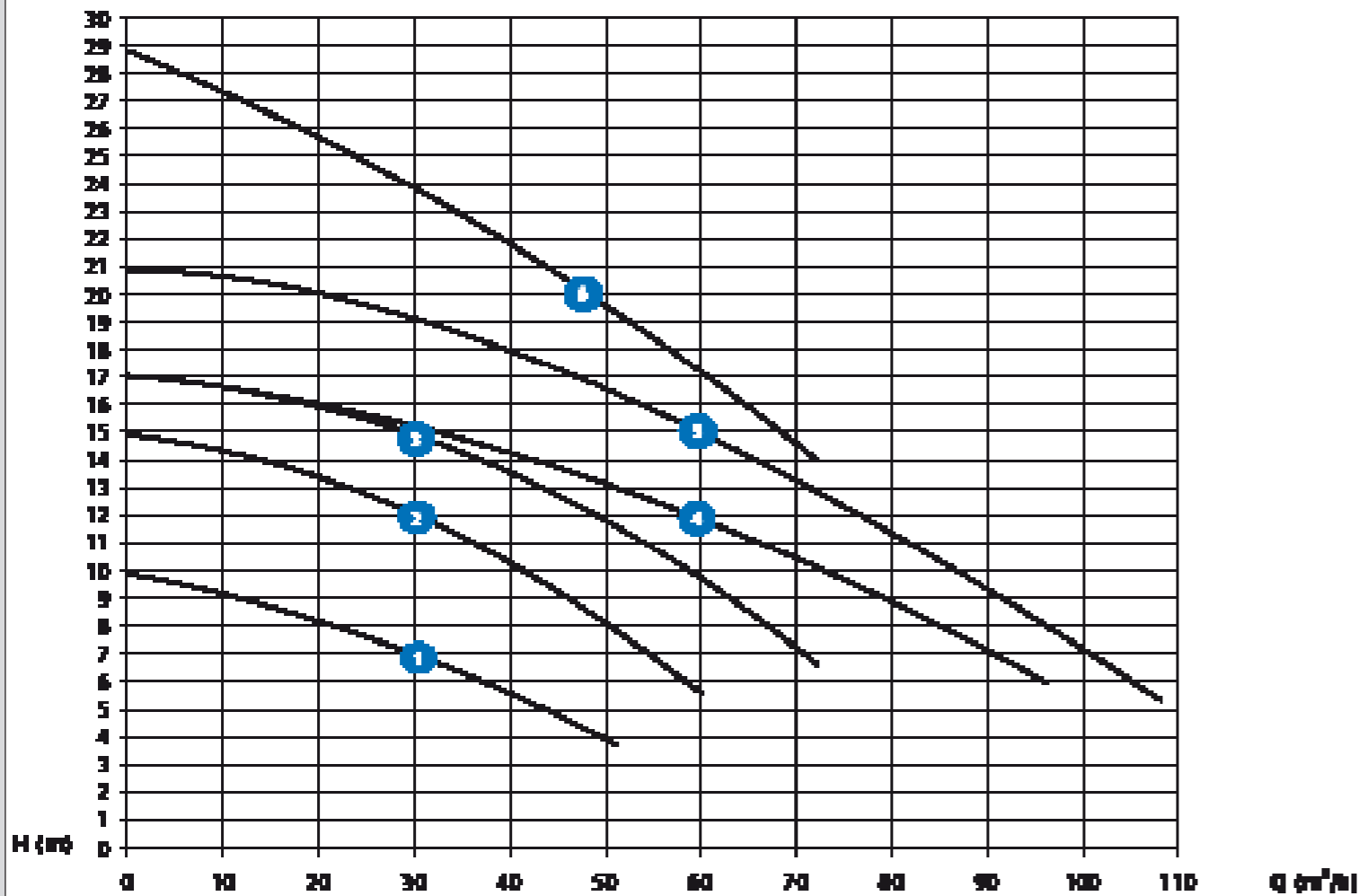

Nr	Type	Outlet (inch) (mm)	Capacity (m³/h)	Manom. head (m)	Particle size (mm)	Power (kW)	Poles (P)	Revolution (1/min) 50Hz	Current (A) 400V	Electr. cable	Weight (kg)
1	DP 3	3 80	30	7	20	2.2	4	1430	5.0	4x6mm²	145
2	DP 5	3 80	30	12	20	3.7	4	1430	8.3	4x6mm²	165
3	DP 7.5	3 80	30	15	25	5.5	4	1445	11.8	4x10mm²	195
4	DP 7.5B	4 100	60	12	25	5.5	4	1445	11.8	4x10mm²	195
5	DP 10	4 100	60	15	25	7.5	4	1445	16.3	4x10mm²	215
6	DP 10H	4 100	48	20	14	7.5	4	1445	16.3	4x10mm²	225

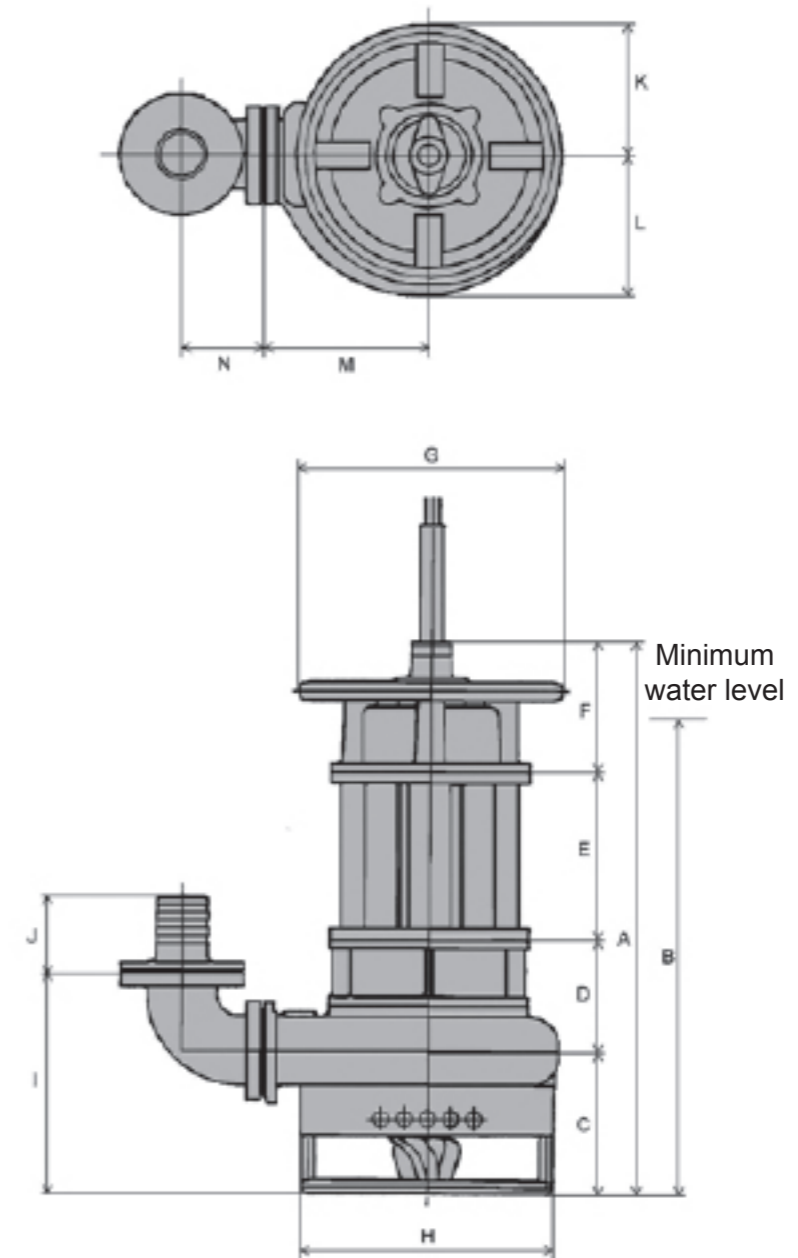

DIMENSIONS (mm)		A	B	C	D	E	F	G	H	I	J	K	L	M	N
1	DP 3	758	680	200	160	235	190	360	320	320	115	180	190	240	123
2	DP 5	840	700	200	160	290	190	360	320	320	115	180	190	240	123
3	DP 7.5	850	700	220	170	260	200	400	380	340	115	200	215	250	123
4	DP 7.5B	850	700	225	165	260	200	400	380	385	143	200	225	250	163
5	DP 10	890	740	225	165	300	200	400	380	385	143	200	225	250	163
6	DP 10H	890	740	225	165	300	200	400	440	385	143	230	255	280	163